

LOADS CARGAS

Counterweight Contrapeso	Jib Length Comprimento da lança	Kg / m		m	12	15	23	28	33	40	45	50
		5000	2500									
13000kg	50 m	28,4 m	5000	5000	2500	2500	2500	2500	2100	1600	1400	1250
5x2000kg+2x1500kg	L51+L52+L53+L42+L43+L44+L45	15,2 m	5000	5000	5000	3200	2500	2100	1600	1400	1250	
11500kg	45 m	29,5 m	5000	5000	2500	2500	2500	2200	1700	1500		
5x2000kg+1x1500kg	L51+L52+L53+L42+L43+L45	15,8 m	5000	5000	3300	2600	2200	1700	1500			
11000kg	40 m	30,3 m	5000	5000	2500	2500	2500	2200	1800			
4x2000kg+2x1500kg	L51+L52+L53+L42+L45	16,2 m	5000	5000	3400	2700	2200	1800				
9000kg	33 m	30,1 m	5000	5000	2500	2500	2500	2250				
3x2000kg+2x1500kg	L51+L52+L53+L43+L45	16,2 m	5000	5000	3400	2700	2250					
7000kg	28 m	28 m	5000	5000	2500	2500	2500					
2x2000kg+2x1500kg	L51+L52+L53+L45	15 m	5000	5000	3100	2500						
5000kg	23 m	23 m	5000	4000	2500							
1x2000kg+2x1500kg	L51+L53+L45	12,3 m	5000	4000	2500							

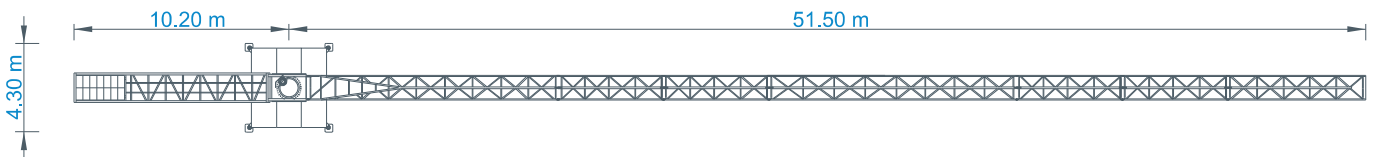
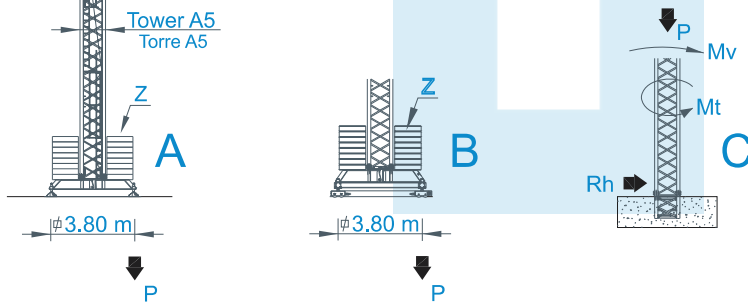

REACTIONS REACCIONES

BALLAST TABLE AND MAXIMUM REACTIONS FOR ALL JIB VERSIONS
TABELA DE LASTRO E REAÇÕES MÁXIMAS PARA TODAS AS VERSÕES DE LANÇA

H m	A / B		C			
	Z kN	P kN	Mv kNm	P kN	Rh kN	Mt kNm
21	450	347	882	333	22	66
24	450	354	908	342	25	66
27	450	363	942	351	29	66
30	450	372	982	360	32	66
33	500	395	1026	369	35	66
36	500	406	1075	378	38	66
39	600	443	1127	387	41	66
42	750	494	1185	396	45	66

CHARACTERISTICS CARACTERÍSTICAS

Motions Movimento	Speed Velocidade	Motor's power Pot. dos motores
Hoisting Elevação	0 a 88 m/min.	15 kW
	0 a 44 m/min.	
Slewing Orientação	0 a 1 r.p.m.	2x3 daN.m
Trolleying Distribuição	0 a 60 m/min.	3 kW
Travelling Translação	15 m/min.	2x3 kW
Electric power / Potência total		30 kVA
Tension / Tensão		400 v ±5% (50 Hz)

* Option / Opção

PARTS ELEMENTOS

		A (m)	B (mm)	C (mm)	Peso (kg)
Jib section Lançã L51		11950	1300	2250	2900
Jib section Lançã L52		5200	1160	1650	535
Jib section Lançã L53		5200	1160	1650	510
Jib section Lançã L42		11820	1160	1210	820
Jib section Lançã L43		5100	1160	1210	260
Jib section Lançã L44		5100	1160	1210	230
Jib section Lançã L45		6570	1300	1350	290
Tower section 12m Tramo torre 12m A5		11985	1160	1160	2800
Tower section 6m Tramo torre 6m A5		6075	1160	1160	1510
Tower section 3m Tramo torre 3m A5		3120	1160	1160	870
Telescopic section Tramo telescopagem A5		3090	1385	1385	890
Head section Cabeçote		2150	1320	2320	2800
Counter-jib Contra-lançã		9350	1380	560	2000
Cross shaped base Chassis		5530	500	750	1250
Cross shaped base Chassis		2270	360	750	635
Ballast Contra-peso		1160	320	2405	1500
		1160	330	2950	2000
Foundation Tower Tramo de encastrar A5		1275	1160	1160	450

LOAD DIAGRAM DIAGRAMA DE CARGAS

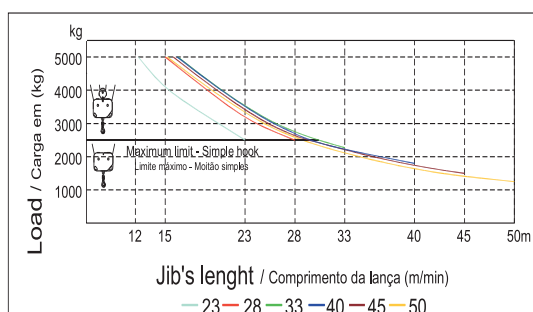

SPEED DIAGRAM DIAGRAMA DE VELOCIDADE

